



National  
Defence

Défense  
nationale

# Maritime Engineering Journal

Canada's Naval Technical Forum



Spring  
2024

## Featured Content

Implications of Passive Fire Barriers  
on RCN Firefighting Tactics



Canada



Photo by MCpl Trevor Matheson, Formation Imaging Services

**The Naval Technical community's  
Honorary Captain (N) Jeanette Southwood, standing fourth from  
the right, joined the Canadian Leaders at Sea program last November  
for an immersive two-day RCN familiarization at sea and ashore.**

**See page 4**



**Director General Maritime  
Equipment Program  
Management**

Commodore Keith Coffen, CD

**Senior Editor**

Capt(N) Sean Williams, CD  
Chief of Staff MEPM

**NCM Editorial Advisors**

CPO1 Paul Parent, MMM, CD  
DGMEPM Unit Chief

CPO1 Chris Magee, CD  
DNPS 3-3, DGMEPM

**Project Manager**

Lt(N) Chris Leung

**Production Editor/Enquiries**

Brian McCullough  
MEJ.Submissions@gmail.com

**Production Co-editor**

Jacqueline Benoit

**Graphic Design  
and Production Services**

d2k Graphic Design & Web  
www.d2k.ca

**Maritime Engineering Journal  
on Canada.ca:**

<https://www.canada.ca/en/department-national-defence/corporate/reports-publications/maritime-engineering-journal.html>

**Our complete back catalogue  
is maintained at:**

<https://publications.gc.ca/site/eng/9.507873/publication.html>

**... and by the**

**Canadian Naval Technical**

**History Association at:**

<http://www.cntha.ca/publications/m-e-j/>

# Maritime Engineering Journal



(Established 1982)  
Spring 2024

## Commodore's Corner – Guest Commentary

The National Shipbuilding Strategy's Value Proposition for DND as Viewed Through the In-Service Support Lens

by *Commodore Michel Thibault, CD* ..... 2

## Forum

Letters to the Editor.....3

Honorary Captain (Navy) Jeanette Southwood calls the Canadian Leaders at Sea Program an “impactful experience”

by *Jacqueline Benoit and Brian McCullough* .....4

Why Confidence can be a Liability

by *Dhilip Kanagarajah* .....5

## Feature Articles

Implications of Passive Fire Barriers on Royal Canadian Navy Firefighting Tactics

by *LCdr Peter O'Hagan* ..... 8

Aegis Integration in Canada's Surface Combatant Program —  
A Revolutionary Increase in Maritime Capability

by *Cdr Bobby Gilpin*..... 13

A Proposal to Improve Quick Acting Watertight Door Handle Holdbacks

by *MS Jesse Besaw* ..... 18

## Titles of Interest

Atrocity on the Atlantic: Attack on a Hospital Ship During the Great War..... 21

Warriors and Warships: Conflict on the Great Lakes and the Legacy of Point Frederick .....21

## News Briefs

Night move for HMCS *Corner Brook*..... 22

Growing capabilities at FMF Cape Scott with new underwater technology..... 23

## CNTHA NEWS

Déjà vu: Looking Back at the Story of the Wartime Wreck of HMCS *Athabaskan* .....24



Test fire created at UWaterloo in support of PG studies into RCN shipboard firefighting safety.

Photo by LCdr Peter O'Hagan

The *Maritime Engineering Journal* (ISSN 0713-0058) is a **NATO UNCLASSIFIED** publication of the Canadian Armed Forces, published by the Director General Maritime Equipment Program Management, 101 Colonel By Drive, Ottawa, Ontario, Canada, K1A 0K2. Views expressed are those of the writers and do not necessarily reflect official opinion or policy. For all enquiries, including free subscriptions, please contact: MEJ.Submissions@gmail.com.

To request a **free subscription, change a delivery address, or cancel a subscription**, please contact: MEJ.Submissions@gmail.com.

## COMMODORE'S CORNER – GUEST COMMENTARY

# The National Shipbuilding Strategy's Value Proposition for DND as Viewed Through the In-Service Support Lens

By Commodore Michel Thibault, CD

**I**t gives me great pleasure to write this guest edition of the Commodore's Corner, and I thank Cmdre Keith Coffen for affording me this opportunity.

As Project Manager for the Canadian Surface Combatant project (CSC), I perform my duties within the framework of the National Shipbuilding Strategy (NSS), and experience at first hand not only its challenges, but also its benefits. Since its launch more than 13 years ago, criticisms of the NSS have been numerous, and some with good reason. But in focusing on its cost and schedule performance, these analyses often overlook one of the NSS's most tangible and strategic benefits that our community requires to conduct its business for the RCN: that of in-service support (ISS).

Canada, as a maritime nation, ought to be able to provide the entire spectrum of ISS to its fleet during times of peace, and periods of conflict. Our ability to do so is fundamental to Canadian sovereignty. To deliver on this strategic responsibility, Canada must maintain certain key enablers—supply chains with sufficient depth and flexibility, ready access to a qualified and experienced industrial base, and up-to-date domestic shipyard infrastructure.

The world learned many painful lessons about supply chain availability during the COVID-19 pandemic. At the onset of the pandemic in early 2020, the Department of National Defence (DND) established a small Tiger Team within the Chief of Staff Materiel organization to focus on essential Canadian Armed Forces (CAF) capabilities. This team assessed and monitored supply chain integrity and availability, and identified in the process an excessive dependence on industry for maintenance services, and on foreign suppliers for the support of some CAF fleets.

The RCN benefits from having ready access to the organic, highly skilled engineering and maintenance services of the Fleet Maintenance Facilities inside its dockyards, but we also need access to a dependable domestic industrial base and supply chain to ensure sufficient support of our naval fleet. These two elements are best established through the design and build phases of large shipbuilding projects. Projects like CSC will leverage

the full range of government instruments and purchasing power to maximize domestic involvement. For example, the NSS Value Proposition requires that its large-vessel shipyards make strategic investments equal to 0.5% of their NSS contracts. These investments must contribute to the broader Canadian marine industry, specifically in human resources development, technology investment, and industrial development. Additionally, under the Industrial and Regional Benefits policy (now Industrial and Technological Benefits policy), NSS shipyards must undertake business activities in Canada equal to the total value of their contracts.

Our history shows that essential enablers such as these can only be realized through build-in-Canada programs. For example, without the financial incentive provided by the government through design-and-build contracts, domestic shipyards aren't likely to make the necessary investments in their infrastructure to ensure they have the required capability to support the RCN fleet. When Canadian naval units are deployed on short notice, they invariably do so in company with our close allies, but we cannot (and should not) rely on the availability of allied repair facilities whenever one of our ships unexpectedly requires the services of a shipyard. It is imperative, therefore, that Canada invest in a substantial domestic refit and repair capability to ensure reliable in-service support for our Navy, and thereby help maintain our role as an actively contributing nation to international peace and security.

*(Continues next page...)*



DND photo by Neil Clarkson

I am keen to continue the work of my predecessors by ensuring that the industrial and supply chain foundations are maximized for the future CSC ISS structure, and are ready to support the RCN for decades to come. The NSS helps preserve Canada's sovereignty by maintaining access

to a responsive and adaptable supply chain, capable domestic shipyards, and the necessary industrial base to support Canada's fleet.



## FORUM

### Letters to the Editor

Editor,

I have just read through the superb special edition of the *Maritime Engineering Journal* covering the Arctic and Offshore Patrol Ship Project [MEJ 102, Fall 2022].

I did notice what seems to be a mislabelled Figure 3 on page 36, which reads in part, "...the surveillance radar on top, and the S-band navigational radar situated lower and forward." I would submit that the proper notation would state that the S-band surveillance radar is on top, and the X-band navigational radar is situated lower and forward.

This division of radar bands according to function can be traced (in an RCN context) at least as far back as HMCS *Haida's* AN/SPS-6C S-band surface surveillance radar and Sperry Mk-2 Marine X-band navigational radar in the 1960s.

Sincerely,

**Cdr Pat DC Barnhouse, OMM, CD, RCN(Ret'd)**



[Ed. Note: Cdr Barnhouse joined the RCN's Electrical Branch as a cadet in 1952, and served as Electrical Officer aboard the Tribal-class destroyer HMCS *Haida* (G63). He retired from the Navy as a Combat Systems Engineer in 1989, and is currently Chairman of the Canadian Naval Technical History Association.]



Pat Barnhouse

Greetings,

I have been quite overawed by the two articles concerning me that appeared in the winter 2023-2024 issue of the *Maritime Engineering Journal*. [Ed. Note: See the Commodore's Corner, and CNTHA Newsletter in MEJ 106.]



I was privileged to have served during challenging times, some of which is recorded in my wartime saga titled *Last Man Standing*. I have just decided to set down my post-war story, to be titled *Still Standing*, to be finalized this year.

A Bravo Zulu to one and all.

Cheers,

**Rolf Monteith, Plymouth, UK**



### Submissions to the *Journal*

The *Journal* welcomes unclassified submissions in English or French. To avoid duplication of effort and ensure suitability of subject matter, contributors are asked to first contact the production editor at [MEJ.Submissions@gmail.com](mailto:MEJ.Submissions@gmail.com).

## FORUM

## Honorary Captain (Navy) Jeanette Southwood calls the Canadian Leaders at Sea Program an “impactful experience”

By Jacqueline Benoit and Brian McCullough

**H**Capt(N) **Jeanette Southwood**, the Engineers Canada VP for Corporate Affairs and Strategic Partnerships who has been affiliated with the RCN’s Naval Technical branch since 2021, had a chance to go to sea with the Navy late last year. She was one of five special guests invited to participate in the Canadian Leaders at Sea (CLaS) program on board HMCS *Fredericton* (FFH-337), and at CFB Halifax, Nov. 28-29, 2023.

CLaS provides opportunities for Canadians to learn and experience more about the Royal Canadian Navy through a hands-on and fully immersive approach both at sea and ashore. During their activity filled two-day program, HCapt(N) Southwood and her colleagues had an opportunity to meet with members of the Canadian Armed Forces, and tour several naval ships and shore installations before returning to their civilian jobs.

Preparations for the overnight sail aboard *Fredericton* began with an early morning welcome and kit issue, followed by a shipboard safety briefing and orientation. HCapt(N) Southwood explained she appreciated being advised to take a slow-release Gravol prior to their sail, as the ship experienced some motion in the three-metre seas outside Halifax Harbour.

“We had been told it was normal for the ship to sail in seas like this,” she said. “Most of us felt fine, and were able to enjoy the soup we were served in the wardroom at stand easy.”

The CLaS guests received help setting up their racks (bunks) and putting away their kit before joining in on the demonstrations and drills that were planned for them. These included observing a person overboard exercise, a demonstration on donning firefighting equipment and handling fire hoses, and live weapons firings. The guests had an exciting opportunity to fire the ship’s 50-cal. machine guns themselves.

To round out a more authentic shipboard experience, the CLaS participants were able to speak to as many sailors as possible in their workplaces, and in the various messes.



Photo by MCpl Trevor Matheson, Formation Imaging Services

HCapt(N) Southwood on board HMCS *Fredericton* (FFH-337) for the Canadian Leaders at Sea program in 2023.

After supper, they enjoyed a fireside chat with Commanding Officer **Cdr Matt Mitchell**, followed by a movie night (*Top Gun Maverick*) with snacks.

“I learned a great deal about what drew the sailors and the CO to their careers in the navy, and what some of their experiences had been,” said HCapt(N) Southwood. “I also had a chance to share my career path as an engineer.”

After a long, busy day at sea, it was time to turn in for the night. With the motion of the ship, HCapt(N) Southwood said she was happy to report she had a restful sleep. The next morning after breakfast, and following engineering rounds, the ship returned alongside HMC Dockyard where the CLaS participants disembarked to begin the next segments of their program.

The group toured the Navy’s new Arctic and offshore patrol vessel HMCS *Max Bernays* (AOPV-432), before being transported from the dockyard to visit several shore installations at CFB Halifax. At Building S120, the RCN’s comprehensive new training facility that includes a three-storey mock-up of the interior of a ship to provide sailors with realistic training while ashore, the CLaS visitors participated in a laser shoot in the facility’s small arms simulator.

(Continues next page...)

The CLaS program concluded with a visit to the nearby Naval Museum of Halifax, where Nova Scotia Lt. Gov., **The Honourable Arthur J. LeBlanc**, officiated at the grand opening of a new exhibit.

“All in all, it was an impactful experience,” HCapt(N) Southwood said. “My thanks go out to **VAdm Angus Topshee** and **RAdm Josée Kurtz** for the invitation to participate in CLaS, to FMFCS CO **Capt(N) Jonathan Lafontaine**, **HMCS Fredericton** and **HMCS Max Bernays**, program coordinators **LCdr Will Sarty**, **LCdr Sonya Sowa** and **Lt(N) Ben Mason**, and all of the other wonderful people who were involved in making our CLaS experience a success.”



HMCS *Fredericton* Marine Technician PO2 Adam DeLauw conducts an engineering tour for the CLaS visitors.

## FORUM

# Why Confidence can be a Liability

By Dhillip Kanagarajah

**A**s far back as history can see, innovation and progress have always rested upon the foundations of skepticism and doubt—not confidence. For example, if there had persisted an enduring certainty and confidence in Newtonian physics, there never would have been good reason to develop a theory of general relativity to provide us with a better model for describing the universe, and in turn unleash new technological developments. Although we live in a milieu that prizes confidence, it just might be that its very antithesis—skepticism and doubt—is the unseen catalyst necessary to deliver progress and improvement.

A niche area in our business of naval technical support, where the sirens of confidence can sometimes enchant, is the domain of technical-data requirements. Technical data, for our purposes, can be defined as the information that is needed to operate and maintain the Royal Canadian Navy's ships and equipment. It manifests itself as technical manuals, documented plans for spare parts, training materials, logistics support analysis records, etc., and is often colloquially referred to as the “paper ship.” Technical data requirements are the conditions that deliverables containing this information must meet before they can be accepted from the contractor; they are abstract technical desires awaiting consummation. The ability to effectively transform abstract technical needs into a statement of work (SOW) often plays an underestimated, but key role in a project's success.

The development of successful technical requirements entails two important dimensions. The primary factor is related to the degree of depth and detail, or how well the customer understands their own requirements; and the secondary factor is related to how well those requirements are articulated such that they are understood by the contractor in the way the customer intended.

### Deep-diving the details

Do you truly understand your requirements? If I had to wager, I would be inclined to bet against you. It's becoming increasingly more difficult to find in-house subject-matter experts who have first-hand, in-depth understanding of the details of their own technical requirements. From the revolving door of staffing turnover to the outsourcing of departmental work, there are various factors that can contribute to the debasement of in-house expertise in “depth and detail.” In its absence we lose the ability to ask the right questions to be able to critically assess the recommendations of external agents, and a kind of blind faith often permeates out of necessity. The result is a false confidence that masquerades like the real thing. In such a scenario, adopting an ounce of skepticism is well worth a pound of confidence.

*(Continues next page...)*

When it comes to the alchemy of requirements, it is the divine (not the devil) that is in the details. The fabric of project success draws its strength from the threads of detail, and unfortunately it is quite easy to become confident in thinking your technical requirements contain the necessary details, when often they do not. Project risk increases when technical requirements are described vaguely or without adequate detail, as this gives the contractor the opportunity to define that ambiguity, however unintentionally, in a way you might find unacceptable. For example, if you were to establish an ambiguous requirement for a “medium pizza” without any detail about the desired or excluded toppings, you should be prepared to accept delivery of *any* medium pizza, regardless of which toppings it is delivered with.

A common misconception is that the addition of greater detail in technical requirements is somehow synonymous with being prescriptive (i.e. telling the contractor how to do the work), and should therefore be avoided. While they are interrelated, they are not entirely the same thing. For example, clarifying the desired or excluded pizza-toppings is not the same thing as telling the contractor how to make the pizza. Of course, establishing constraints influences how the pizza is made, but the clarification of those nuances and details is really the whole point of requirements-definition.

Another ill-conceived belief is that stating ambiguous or vague requirements is somehow strategic in providing greater flexibility and room to manoeuvre down the road. More often, this is a rationalization to avoid spending the time and effort needed to understand your own requirements in sufficient detail, which can hamper the very goals you set out to achieve from the outset.

A similarly flawed strategy that is sometimes confidently embarked upon in the absence of depth and detail is the “iterative approach,” whereby the customer doesn’t know exactly what they want, but feels they will know it when they see it. To continue with the pizza analogy, the pizzeria (i.e. the contractor) would have to undergo an iterative process of delivering a pizza to the customer, receiving feedback on how to modify it with extra cheese, going back to make the change, then redelivering it only to discover that now the customer also wants mushrooms on it, and so on until the pizza satisfies the customer. There are two problems with this when dealing with complex naval technical requirements. For starters, if you don’t actually know what you need in the first place, how can you possibly hope to magically conjure up this knowledge to know when to stop the process? And secondly, iterations incur costs that could easily have been avoided had the necessary time and effort been put into reflecting on your needs, and defining the requirements appropriately.

A cognitive bias known as the *false consensus effect* is another reason why requirements are sometimes described ambiguously and vaguely. This occurs when people confidently believe that their own views, opinions, conclusions, and unstated assumptions are shared by everyone else; as a result, necessary details are omitted from the technical requirements because they are thought to be obvious, and therefore redundant. The pernicious and powerful influence of such cognitive biases is exemplified by the “Jastrow illusion” image of the two curved objects below. We are unconsciously deceived into believing that Object B is longer than Object A, when, in fact, they are identical.

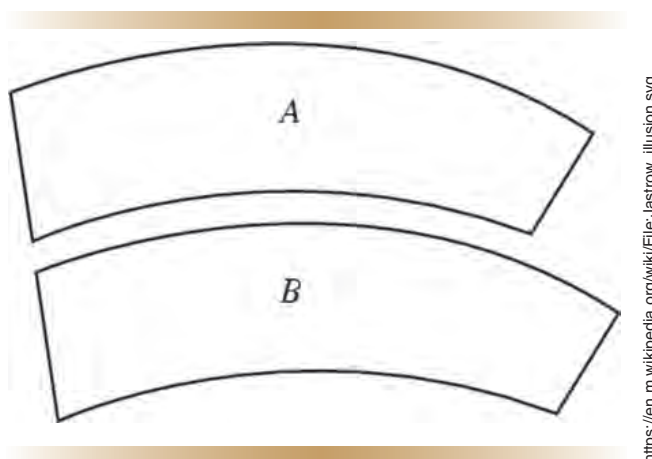

[https://en.m.wikipedia.org/wiki/File:Jastrow\\_illusion.svg](https://en.m.wikipedia.org/wiki/File:Jastrow_illusion.svg)

There are times when our confidence can beguile us into infusing requirements into a SOW for the wrong reasons. A requirement might be included because it is deemed to “add value,” but without any formal assessment having been conducted to determine whether the added value is worth the cost. It is easy to conclude if a particular requirement brings value to the organization, but it is much more difficult to determine if the cost justifies the benefit. The value-for-money assessment can be difficult in the absence of a clear understanding of the causal chains of how a particular technical data requirement links to support larger organizational objectives or processes. It is also made more challenging when the contractor is not required to provide a detailed cost breakdown at a granular level for that specific requirement. At other times, technical data requirements might also be misguidedly included in a SOW simply out of habit (“*That’s what has always been done in the past...*”), or social mimicry (“*That’s what all the other projects do...*”).

## Articulating requirements

The second factor that contributes to the success of technical requirements pertains to how they are articulated—that is, whether they are articulated in a way that the



target audience understands them as you intended. Here, confidence can play a deceptive role. Just as a simple hand gesture can be interpreted differently depending on where you are in the world, so too can be the interpretation of a technical requirement. The implicit assumptions tied to the meanings of words and sentences are not necessarily universal, and the *false consensus effect* can imbue us with a false sense of confidence. This is the same problem that the parable of *The Blind Men & The Elephant* warns us about, in which a number of people who are unable to see the elephant as a whole will describe the animal in different ways depending on their own limited perspective. This prompts us to ponder how we might describe a requirement in such a way that it is understood as intended.

As technical-data requirements are developed, one possible approach could be to think about them as being more evaluative and less descriptive. In other words, perhaps we should endeavour to be writing SOW requirements more like how we might evaluate the resulting deliverable, and less like we are trying to describe the requirement. This might be beneficial in two ways. First, thinking about the criteria that would be used to assess the resulting deliverable tends to better sharpen our ability to describe the requirement in greater detail; and consequently, will leave less room for any ambiguity in how it is interpreted by the contractor. The second benefit accrues when the end-product has been delivered, and is being assessed by the evaluation team. Here, well-defined, quantifiable requirements will support easier assessment of the deliverables, prevent contractual disputes over ambiguities, and ensure that what was delivered is indeed what was desired.

Artificial deadlines present their own problem in that they encourage us into rationalizing unwarranted confidence in the quality of our stated requirements, such that we will endorse a SOW, even though it has deficiencies, simply to meet a deadline. Inevitably, any overlooked issues will result in greater schedule delays than the time you may have originally saved. As retired United States Marine Corps lieutenant-general and serving US representative Jack Bergman once said, “There’s never enough time to do it right, but there’s always enough time to do it over.”

Another similar misguided strategy for saving time involves the ongoing management of requirements following contract award. In this case, agreements are made at meetings or by email to modify or clarify requirements without updating the SOW, and over time these accumulated changes are often lost to history through staffing turnovers and fading memories. As a result, significant additional

workload is introduced when trying to retrace and understand such “phantom agreements” in an attempt to reconcile why the delivered end-products are misaligned with the SOW requirements—time and effort that could easily have been avoided through more diligent record-keeping.

“There are times when our confidence can beguile us into infusing requirements into a SOW for the wrong reasons.”

And for the same reason you should never ask a barber if you need a haircut, it is important that your requirements are critiqued (even better, endorsed) by an independent, arms-length body. Groupthink can often imbue a false sense of confidence in the quality or correctness of your own requirements, and without an arms-length review, it can be challenging to recognize your own blind spots.

### Asset or liability?

Why is there such a predisposition to confidence? Self-enhancement theory suggests that humans have a basic need to perceive themselves positively to enhance or maintain the value they place on themselves (i.e., self-esteem), and therefore confidence is a tool we unconsciously employ to achieve that end. In other words, the design-intent of humans seems to be more about feeling good (and avoiding displeasure), and less about recognizing truth. Innate cognitive biases can also foster a sense of confidence.

Although confidence can be a useful springboard for action and decisiveness, and even beneficial to boosting one’s self-esteem, it is a double-edged sword that can sometimes become an unrecognized liability. Perhaps what’s needed is a rebalancing of sorts. Perhaps we should be encouraging and reinvigorating the values of skepticism and self-doubt, such that we are better protected against the fallibilities of confidence.



*Dhilip Kanagarajah is the Integrated Logistics Support Engineer for the Arctic and Offshore Patrol Ship (AOPS) Project in Ottawa.*

## FEATURE ARTICLE

# Implications of Passive Fire Barriers on Royal Canadian Navy Firefighting Tactics

By LCdr Peter O'Hagan

Shipboard firefighting affects all of us who work in and around the fleet, and is something that has piqued my professional interest for more than a decade. Inspired by the work of **Cdr Tom Sheehan, RCN (Ret'd)** on aerosol-based products for fire suppression (MEJ 75, Fall 2014), I went on to complete my own M.A.Sc in marine fire safety University of Waterloo under the Canadian Armed Forces' sponsored postgraduate program (which I highly recommend).

The focus of my study came about during a previous posting as the Target State Coordinator for the National Shipbuilding Strategy. Here I had the opportunity to see how new standards for shipboard equipment are being introduced in the RCN's *Orca* patrol vessels, Arctic and offshore patrol vessels (AOPVs), Joint Support Ships (JSS), and eventually the Canadian Surface Combatants (CSC). The change that really caught my attention was that these new ships are coming fitted with passive fire barriers—specifically, fire-insulated doors and hatches at watertight divisions—that are designed to prevent the transfer of heat from inside a burning compartment to adjacent spaces. The Navy is long used to compartments being water and smoke tight, and has incorporated these factors into its firefighting tactics, but with certain higher risk compartments now being heat-tight as well (albeit for a short period of time), a serious new consideration has been added to the equation.

The new International Maritime Organization (IMO) requirements on fire safety design came into force after the *Halifax*-class frigates were built in the 1990s, which means the Navy has limited experience with how these insulated barriers can impact shipboard firefighting tactics. Since the *non-insulated* steel doors and hatches found in most of our current fleet of major warships allow heat to pass through, sailors have been trained to assess the exterior temperature of a compartment's entryway to get an idea of the conditions inside. In other words, they have a pretty good idea of what they are walking into before they open a door. With *insulated* barriers, however, using this same ingrained tactic could lead to devastating consequences. An insulated door that is cool on the outside might very well be masking a severe fire on the inside.

When I did some research into publicly available references on marine firefighting, I was surprised to learn that this significant difference in assessing compartment fire boundary conditions was not mentioned at all—a potentially big deal for sailors who continue to use the outer temperature of an entry point as part of their firefighting decision loop, as well as for land-based firefighters who are responding to shipboard fires while alongside.

RCN firefighting training teaches a two-tiered response to shipboard fires, consisting of an initial response by a rapid response team (RRT) that uses visual cues and sense of touch to estimate conditions on the other side of a door or hatch, followed by a second response by a fully equipped attack team (AT) that relies on visual cues, along with an infrared temperature readout from a thermal imaging camera (Figure 1). While these tried-and-true tactics work well when heat is allowed to transfer through a door or hatch, they can result in dangerously misleading assessments of what's behind an insulated barrier that is designed to confine the heat of a fire to inside a compartment.

Although the IMO certification testing demonstrated that the noncombustible mineral wool used as fire insulation (Figure 2) will prevent the unexposed side from exceeding a threshold temperature within a specified time rating, it does not provide the full temperature data to understand how hot the unexposed side gets during the testing time, or what it might look like during the stages of

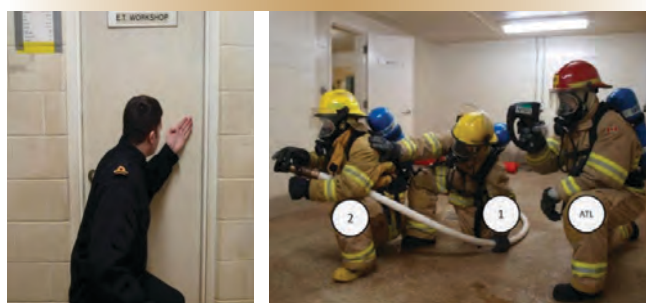

Figure 1. The RCN's two-tiered response to shipboard fires: A back-of-the-hand door temperature check by a member of the Rapid Response Team, followed by a fully equipped Attack Team armed with a thermal imaging camera.

DND photos courtesy the author



Figure 2. Rockwool A-15 insulation installed on the test bulkhead, showing exposed longitudinals, simulated door dogs and handle which were exposed to fire.



Figure 3. Bulkhead test unit external view, and the burn compartment.

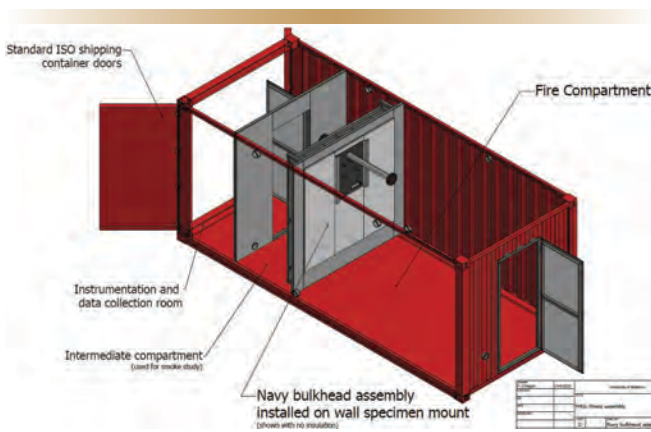

Figure 4. Bulkhead test unit diagram showing the compartmentalization and the Navy bulkhead assembly installed. No. 10-gauge steel panels were installed below the Navy bulkhead assembly portion to have a complete steel bulkhead across the frame mount.

the response. The underlying purpose of my thesis, therefore, was to create experimental compartment fire conditions that would deliver real data on the differences between insulated and non-insulated barriers, and allow me to capture videos and images that could serve as useful visual aids in future RCN firefighting training.

Because the IMO certification testing on the insulated barriers was done on unpainted steel—and rust is a killer, so we paint everything—I also wanted to investigate what happens when you take the certified materials and expose them to a “real-world” fire situation with a painted structure penetrated by piping and cables. How paint responds to fire is a key piece of information for determining the firefighting tactics. My full thesis describes the small-scale testing that was developed to evaluate how the fire insulation interacts with a painted structure, and predict how the surface temperature relates to various visual cues (such as when the paint on the unexposed side begins to smoke, blister and eventually burn). The key takeaway there is that for rapid response, at temperatures where the surface will be hot enough to cause 2<sup>nd</sup> and 3<sup>rd</sup> degree burns, there will be no visual cues, with the paint only beginning to off-gas at 70°C, and some discoloration becoming evident at temperatures exceeding 100°C.

What follows is a description of the large-scale fire tests that were conducted on a simulated marine compartment bulkhead and door to demonstrate the unexposed surface temperatures for both insulated and non-insulated cases.

## Experimental Setup

### Burn Container

The University of Waterloo fire lab has three large-scale test setups that can be configured to suit the goals of various experiments. The first is a two-storey burn house laid out as a modern multi-bedroom dwelling for studying common household fire scenarios. The second is a 20-foot sea container containing a combination burn room and instrumentation space that was set up as “the Navy test unit” by Cdr Sheehan for his 2013 master’s thesis work. The third and newest, the one used for this study, was another 20-foot sea container, divided into a burn room, an intermediate section, and an instrumentation section (Figures 3 and 4). A permanent mounting frame with a 2 x 2-metre opening was configured to support our custom steel test bulkhead and simulated door, designed to replicate a typical watertight division in a ship.

*(Continues next page...)*

The experiments to support this thesis involved 10 large-scale fires with insulation on the representative bulkhead setup, as well as some small-scale testing on painted steel and insulation to get some preliminary results, and to understand how to safely scale these up to a large-scale test. Additionally, because I used the actual paint coating employed on our ships, I was able to estimate the temperatures at which the paint coating will begin to off-gas, bubble, smoke, and then burn.

As part of the initial characterization testing to come up with a design fire, the bulkhead assembly included an opening to simulate a cable pass-through to allow concurrent testing for Defence Research and Development Canada (DRDC) on smoke movement via an open cable gland. These results are available at the internal DG-MEPM/MSC 4-2 SharePoint on the Defence Wide Area Network (DWAN), along with a video showing how effective closing the door was on limiting fire growth. The fire self-extinguished in a little under a minute, with a much lower peak temperature than when the door was left open. The video is also available on YouTube [<https://www.youtube.com/watch?v=L9Le1-RISe8>].

### Data capture

As shown in Figure 5, more than 90 thermocouples were used to monitor the temperature at various key points inside



Figure 5. Thermocouples mounted on the rear of the test bulkhead.

the burn compartment. This setup included thermocouple “trees” in the corners, each tree having eight thermocouples evenly distributed from floor to ceiling, with additional thermocouples ranged along the ceiling to give a clear picture of the fire conditions inside the burn compartment. Thermocouples were also placed at IMO Fire Testing Protocol mandatory points, and point-temperature measurements were taken on the opposite side of the longitudinals, piping, and door handle and dog clips to monitor the most likely “heat-short” paths, as these were not covered by the A-15 (15-minute) insulation on the fire side.

### Results

The series of images in Figures 6a and 6b demonstrate the significant fire-test temperature differences between the insulated and non-insulated test bulkheads. The fire insulation tested with a 15-minute rating was very effective at preventing heat-transfer to adjacent spaces, meaning that the exterior surface temperature could not be used to assess the fire conditions on the other side.

For the rapid response team timeline, the insulated door was cold with no hot spots, even on the handle and dog-clip fastenings, despite the fire being 60 cm from the bulkhead. In the non-insulated case, however, which represents the status quo on the *Halifax*-class ships, the results indicated that the door would indeed be hot, and validated that the current firefighting tactics for checking the outside temperature before attempting entry are effective.

By the time the attack team arrives, infrared heat would be visible in some spots on a 15-minute rating insulated door, and there could be other hot spots at the door dogs, and potentially the handle. However, there would be no visible indication on the paint, as the insulation is significantly masking the severity of the fire.

In the non-insulated case on the same AT timeline, the surface of the door was just under the safety threshold of 500°F, which can be used as a rule of thumb in the decision loop for advancing on a fire. Again, this validated the current RCN standard operating procedures for the *Halifax*-class where no fire insulation is fitted, in that the bubbling paint and heavy smoke would give the attack team a visual indication that there is a fire on the other side of the door.

### Conclusion and Way Ahead

Conducting large-scale fire tests makes for a pretty interesting day at work, but I never lost sight of how serious the real-world situations can be. The inclusion of fire insulation to create passive thermal barriers on ships represents a

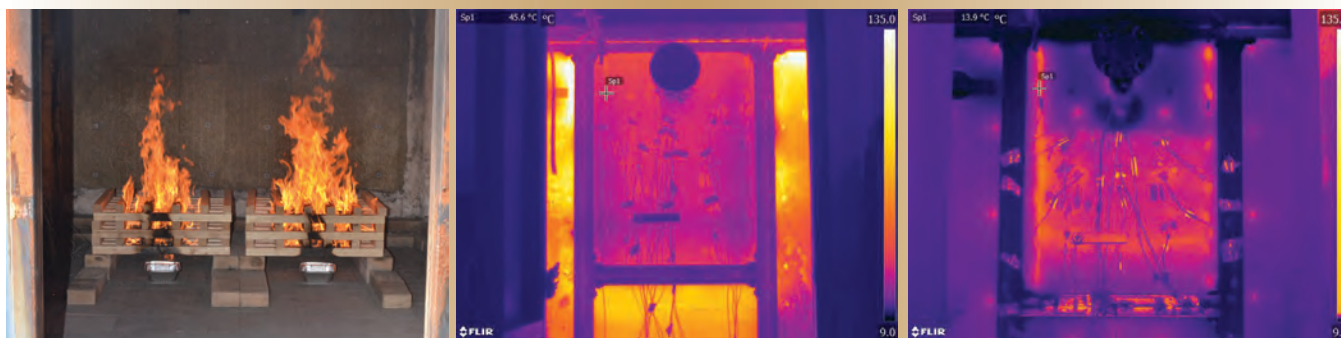

Fire at 4.5 minutes  
Ceiling temp: 150°C (302°F)

Non-insulated door, adjacent space 45.6°C  
(114°F) Hot to touch.

Insulated door, adjacent space 13.9°C (57°F),  
Cold to touch (i.e. ambient temp.)

Figure 6a. Rapid Response timeline: 3-5 minutes after ignition (alarm at 1-2 minutes).



Fire at 10 minutes  
Ceiling temp: 290°C (550°F)

Non-insulated door, adjacent space 254°C  
(489°F). Paint bubbling, heavy smoke.

Insulated door, adjacent space 71°C (160°F).  
Hot to touch (instant 3<sup>rd</sup> degree burns), but no  
indication on paint, no smoke.

Figure 6b. Attack Team timeline: 10-12 minutes after ignition.

significant safety improvement, and its efficacy has been demonstrated in both certification testing, and with actual shipboard fires in the marine world. The results from my thesis work now provide data that show real temperatures on the unexposed side of insulated fire barriers during RRT and AT response timeframes, information that can be used to improve current training, and adjust existing firefighting tactics, decision-making processes, and standard operating procedures used by the RCN. I would be pleased to hear from anyone regarding this research.

Additional testing at the Quality Engineering Test Establishment (QETE) is being planned to better understand the behaviour of paint at higher temperatures, which will hopefully give something like a visual “cue card” to cross-reference temperature ranges with things like discoloration, bubbling, and heavy smoke production. In general, though, if something is happening to the paint, it should be considered a “hot door” without having to touch it.

Work is also continuing at the University of Waterloo with fire testing a spray-on gel product as a possible AFFF replacement for applications such as boundary cooling, as well as for use during first aid firefighting in the initial response.

It pays to remain vigilant. While a cool exterior temperature may still be a good indicator of heat conditions on the other side of a compartment in ships that do not have fire-insulated boundaries, and in spots on new ships where no fire insulation has been installed, the use of fire insulation in locations throughout the ship means that a general rule of thumb is no longer valid, and a more specific compartment-by-compartment approach is needed. This is where simple changes like door and hatch markings to indicate where the fire insulation is installed will help during an emergency response. The markings in the DC manual are currently being updated, with the specific plans for AOPVs and other classes planned.

*(Continues next page...)*

The introduction of passive fire barriers will also require changes to how we maintain the insulation in service. The common practice of applying a marine enamel paint coating to insulation is not recommended, as it undermines the effectiveness of the IMO certified mineral wool product used as the fire barrier. Furthermore, not reinstalling fire insulation following repairs could have a significant impact on shipboard firefighting.

I am hoping this article helps spread a bit of awareness, and assists with the continuing evolution of the RCN's firefighting tactics to adapt to the new design features coming in with the fleet recapitalization under the National Shipbuilding Strategy. While the videos and IR imagery produced for my thesis work will help in the short term, I am optimistic that passive fire barriers can be incorporated into the INFERNO project Class A live fire trainers at the Damage Control Training Facilities as a removable feature to reflect the new ship designs. It is one thing to be told that the exterior door of a burning compartment may be safe to touch, and another thing entirely to place your bare hand on a door that has a +500°F fire blazing away on the other side of it, and have it feel cool to the touch.



*LCdr Peter O'Hagan is a Naval Technical Officer with the Major Surface Combatant directorate of the Maritime Equipment Program Management division (DGMEPM)*

## Acknowledgments

The guidance of master's program supervisor **Dr. Elizabeth Weckman** from the Department of Mechanical and Mechatronics Engineering at University of Waterloo, Ontario is gratefully acknowledged. My sincere thanks also to **Dr. Royale Underhill** at DRDC Atlantic for her support with the experiments, which included funding for the setup and materials. And finally, a note of appreciation for the extensive testing previously conducted by **Cdr Tom Sheehan** at University of Waterloo. It was thanks to his work that I was easily able to build the experimental design fire scenarios used for the present study on the effects of passive fire barriers fitted at watertight divisions.

## Reference

*Investigation on the implications of passive fire barriers on the fire fighting tactics of the Royal Canadian Navy, Master's Thesis (2022), LCdr Peter J. O'Hagan, Master of Applied Science (Mechanical Engineering), University of Waterloo.*

## IMO Safety of Life at Sea, the Naval Ship Code, and Certification of New Ship Builds

NATO countries are collaborating to create common standards that can be used to help guide naval ship builds, while meeting or exceeding the same safety standards as commercial ships. The Naval Ship Code (ANEP 77) was designed to give performance-based rules to achieve safety standards comparable to the commercial SOLAS rules, while recognizing the unique requirements of naval vessels.

For ships built to commercial rules, the NSC requirements overlap with existing class rules. This means that the new builds, which meet SOLAS (via commercial class rules) and/or NSC, now incorporate the fire insulation requirements, with some additional guidance included for naval risks such as ammunition storage. Both SOLAS and NSC use a risk matrix that assigns a risk value to different types of compartments, compares it to the adjacent compartment fire risk, and gives a fire insulation requirement. This can range from no insulation (A-0) required between low-risk compartments, to 15-, 30- or 60-minute insulation barrier ratings between higher-risk compartments.

The insulation is divided into "A" and "B" classes, which specify the maximum temperature allowed on the non-exposed side at the end of the time limit, with "A" class having a lower maximum allowable temperature (i.e. less insulation) compared to "B" class. The A-15 insulation rating used in my thesis study means it was tested to the IMO Fire Testing Protocol, passed the prerequisites for non-combustibility, and in a bulkhead test the average temperature on the unexposed side did not exceed 140°C, with no point temperature exceeding 180°C after 15 minutes while remaining smoke-tight.

A-0 is a bit of a special case, as no fire insulation is installed. However, in order to meet the smoke-tight requirements, any cable, pipe or other penetration needs to be made smoke-tight. This is done by using things like A-60 cable glands and welded pipe penetrations, which in the context of the *Halifax*-class frigates is only seen in watertight divisions. This helps contain the fire and smoke, which improves both the initial escape and evacuation, as well as firefighting efforts, by improving visibility.

— **LCdr Peter O'Hagan**

## FEATURE ARTICLE

# Aegis Integration in Canada's Surface Combatant Program — A Revolutionary Increase in Maritime Capability

By Cdr Bobby Gilpin, P.Eng, MASc, MDS, B.Eng

In a time of escalating global uncertainties, the critical role of an advanced naval force in upholding a rules-based order becomes increasingly apparent. The Navy stands as the vanguard in any conflict, maintaining control of the sea, ensuring theatre air defence, and projecting strategic influence. Recent events, such as the ongoing conflicts in the Black and Red seas, underscore the indispensable need for an advanced surface warfare fleet.

Recognizing the imperative to contribute to global coalitions in the pursuit of a secure and peaceful world order, Canada has embarked on a significant endeavour—the Canadian Surface Combatant (CSC) Project. This initiative aims to overhaul the Royal Canadian Navy's surface combatant fleet, replacing and modernizing capabilities present in the *Halifax*-class frigates and the retired *Iroquois*-class destroyers with a new fleet of Canadian variants of the British Type 26 frigate. The Royal Australian Navy has ordered its own variant of this platform.

Central to the CSC Project lies the integration of the US Navy's Aegis Combat System—an emblem of technological advancement, and a strategic cornerstone in fortifying Canada's naval operational capabilities for a modern warfare environment. Its incorporation into the CSC program signifies not just a leap in technology, but a paradigm shift that promises enhanced operational effectiveness, technological superiority, and seamless cooperation with the US Navy (USN).

## Understanding the Canadian Surface Combatant

Canada, in partnership with prime contractor/builder Irving Shipbuilding Incorporated (ISI), selected the UK's Type 26 frigate parent design presented by Lockheed Martin Canada and BAE Systems for the CSC ship through a competitive Request for Proposal (RFP) process. The Bid Concept Design introduced a revamped combat system (CS), necessitating modifications to the platform systems to accommodate the new CSC design.

Canada's governmental team—comprising the Department of National Defence, Public Services and Procurement Canada (PSPC), and Innovation, Science and Economic Development Canada (ISED)—remains dedicated to ensuring that the Royal Canadian Navy (RCN) receives the necessary capabilities, while upholding value for the Canadian taxpayer by creating opportunities and ensuring the continued vibrancy of our naval industrial base. The CSC successfully exited Preliminary Design Review in December 2022, and is currently progressing through the Functional Design phase that is anticipated to complete by mid-2024. Initial operating capability for the CSC is projected for the early 2030s, supported by a construction program aligned with this timeline.

The Canadian Surface Combatant (Figure 1) is envisioned as an all-purpose major surface combatant capable of above-water warfare, underwater warfare, and information warfare. Additionally, the CSC will carry a single Cyclone CH-148 helicopter, and several small boats to support low-intensity taskings such as maritime interdiction operations, support to special forces, and assistance to other government departments (e.g., Fisheries and Oceans, RCMP, etc.). The CSC's five primary missions are to:

1. Protect Canadian sovereignty.
2. Defend North America.
3. Provide disaster relief.
4. Support United Nations peace operations.
5. Contribute to the security of allies and allied/coalition operations abroad.

To achieve this array of operations, CSC will integrate Aegis as the centerpiece of the combat system. To accommodate non-USN equipment, Aegis is complemented by the Canadian Tactical Interface (CTI), permitting Canada the flexibility to select any major combat system element globally and integrate it into CSC and Aegis. The CSC ship promises to be a significant leap in capability for the Government and RCN, positioning it as one of the most capable warships in the world.

*(Continues next page...)*



Figure 1. The Canadian Surface Combatant variant of the British Type 26 frigate will overhaul the RCN's surface combatant fleet, replacing and modernizing the capabilities present in the *Halifax*-class frigates and the retired *Iroquois*-class destroyers.

## Aegis: A game-changer for the RCN

The Aegis Combat System is built around the Aegis Weapon System, developed by the US Navy in the 1960s and first put to sea in the 1970s. Named after the shield of the Greek god Zeus, Aegis has consistently evolved to keep pace with threats, and follows the mantra, “build a little, test a little, learn a lot.” At its core, the Aegis Weapon System includes the SPY radar, Mk-41 vertical launching system (Mk-41 VLS), and SM-2 Standard Missile, deployed aboard US Navy cruisers of the *Ticonderoga* and *Arleigh-Burke* classes (Figure 2).

Aegis originated from the USN Advanced Surface Missile System (ASMS) Project, initially focusing on anti-air warfare. As it evolved, the Aegis Weapon System transformed into the Aegis Combat System, serving as the hub for various combat systems in the US Navy. Continual upgrades enhanced its command & decision (C&D) capability, integrating multiple warfare areas into a single, multi-warfare combat system. Today, the Aegis Combat System undergoes continuous upgrading by the USN using the Aegis Common Source Library (CSL). This shared software library ensures the employment of standardized software components, tools, and functionalities, thereby guaranteeing consistency, interoperability, and ease of maintenance across various Aegis-equipped platforms, as depicted in Figure 3.



Photo courtesy United States Navy

Figure 2. Coordinated volley of SM-2MR missile firings by four USN Aegis ships: (left to right) USS *Vicksburg* (CG 69), USS *Roosevelt* (DDG 80), USS *Carney* (DDG 64) and USS *The Sullivans* (DDG 68).

This capability is critical for the CSC, as it allows Canada to develop an Aegis Combat System tailored to the specific needs of the RCN through the US Navy's Integrated Warfare Systems 4.0 Group, who are responsible for international Aegis-equipped ships. Australia, South Korea, Spain, and Japan are all using Aegis in their current surface fleets.

## An Aegis-equipped ship for the RCN's future

The CSC Combat System revolves around the Aegis Combat System (ACS); in addition, Canada has chosen to integrate



other systems, outside of the Common Source Library, primarily focused on underwater warfare (UWW), limited electronic warfare, and gunnery. Major equipment items and capabilities are illustrated in Figure 4, providing a concise understanding of the core capabilities of the CSC system as per the Aegis-CSC Combat System architectural arrangement.

## Combat Management System

At the heart of the CSC lies the Aegis Combat System, serving as the overarching C&D tool for the ship. Aegis stands as the most advanced shipboard combat system in the world, capable of all-domain warfare simultaneously. It was designed and operates based on five so-called Aegis cornerstones: Firepower, Reaction Time, Coverage, Environmental Resiliency, and Availability. Built on an open architecture, Aegis allows for future upgrades with minimal disruption, applicable across all Aegis-equipped ships. The CSC Aegis integration centres around the SPY-7 radar, Mk-41 VLS, Weapon Control System, Standard Missile (SM), and major C&D elements. The computing and network infrastructure components for Aegis are commercially sourced, and enclosed in mission-critical enclosures that are protected against shock and vibration for combat survivability.

Several non-US systems being integrated into the Canadian Surface Combatant are absent in the Common Source Library utilized by the US Navy, and require integration into the Aegis Combat System through the Canadian Tactical Interface (CTI). While loosely based on CMS-330, CTI acts as an interface to ensure a coherent combat system. Besides the interface function, CTI assumes the role of the underwater warfare C2 system, reporting tracks to Aegis, and executing Aegis commands from the operations team.

## Above-water warfare

The Aegis Combat System shoulders responsibility for all facets of surface and air warfare in the CSC. It manages the detect-to-engage sequence for anti-air warfare, leveraging the cutting-edge AESA SPY-7 radar to autonomously detect and track contacts, while other components classify and identify system tracks (i.e. IFF, Link, etc.). Upon identifying an above-water threat as hostile, the ACS responds using doctrine-controlled and/or operator-in-the-loop modes via the C&D tool, where the weapon control system commands the various effectors to engage: i.e. Mk-41 VLS (SM2, ESSM), guns, close-in air-defence system, etc.

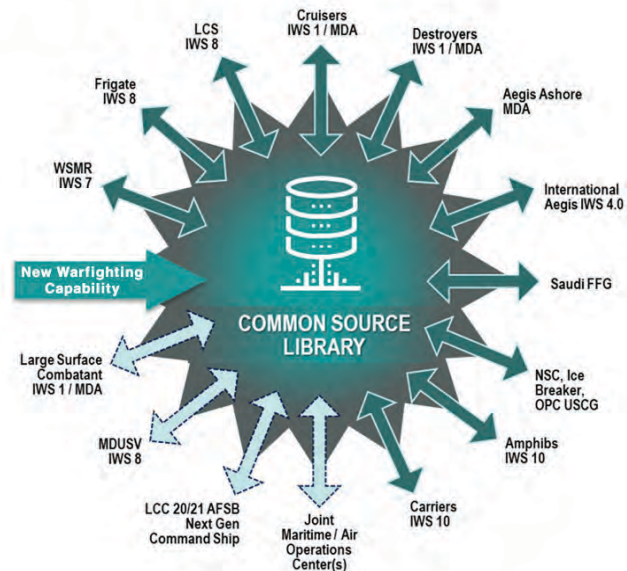

Figure 3. Aegis-equipped ships utilizing the Common Source Library software reference.

In electronic warfare operations, Aegis collaborates with Version 6 of the AN/SLQ-32 “Slick-32” Surface Electronic Warfare Improvement Program (SEWIP Block 2), a radar-electronic support measures system that executes engagement orders for soft-kill measures. SEWIP augments Aegis by providing ESM support for picture compilation, integrating ESM information into Aegis system tracks.

The CSC project selected the NA-30S Mk-2 FCS—a fire-control radar integrated with electro-optical infrared cameras—to facilitate gun engagements. This system controls the Italian Leonardo (formerly Oto-Melara) 127-mm Vulcano lightweight main gun system, capable of launching guided and unguided rounds for direct line-of-sight engagements (surface or air) and naval shore bombardment. Furthermore, the CSC will employ the Naval Strike Missile for surface adversary engagements.

## Underwater warfare

Aligned with its Royal Navy (RN) Type 26 heritage, the CSC emphasizes anti-submarine warfare (ASW). The platform systems operate quietly, and utilize acoustic tiles, making this ship a formidable ASW platform. The CSC incorporates the RN S2150 hull-mounted sonar (HMS), the RN S2170 torpedo defence system, and a towed low-frequency active sonar that is capable of bistatic operation with the S2150 HMS. The Mk-54 torpedo serves as the effector for the UWW

*(Continues next page...)*



Photo courtesy Australia Defence 2019

Royal Australian Navy ship HMAS *Hobart*, an Aegis air-warfare destroyer, fires an SM2 missile off the coast of New South Wales, Australia.

suite, supported by the Mk-331 torpedo settings panel, and a dual-tube launcher on both port and starboard sides of the ship. Additionally, the CH-148 helicopter significantly contributes to the ASW capability.

While Aegis does not directly act as a command & control system for UWW, CSC relies on CTI to manage UWW functionality. The CTI UWW C2 system, still in development, aims to develop underwater tracks and transfer them to Aegis for wider combat system distribution and C&D. Aegis, in turn, sends engagement orders to the CTI UWW C2 system, managing engagements using the Mk-54 torpedo.

Equipment Name	Procurement Path	Integration Path
<b>Aegis Combat System</b>	FMS	Aegis
3D AESA SPY-7 Radar	FMS/DCS combined	Aegis
Cooperative Engagement Capability (CEC)	FMS	Aegis
Radar Electronic Support Measure (ESM) SEWIP Block 2	FMS	Aegis
Identification Friend or Foe (IFF)	FMS	Aegis
Mk-41 Vertical Launch System	FMS	Aegis
Missiles: ESSM Block 2, SM2, Tomahawk	FMS	Aegis
Precision Navigation and Timing (PNT)	FMS	Aegis
Nulka Electronic Warfare Missile Decoy System	FMS	Aegis
Close-In Air Defence System (CIADS) – Sea Ceptor	DCS	Aegis
Surface-to-Surface Missile – Naval Strike Missile	DCS	Aegis
Link 16/22	FMS	Aegis
<b>Canadian Tactical Interface</b>	DCS	CTI
MDA Laser Warning and Countermeasures	DCS	CTI
SRD-506 Communication ESM System	DCS	CTI
Hull Mounted Sonar – Ultra S2150	DCS	CTI
Surface Ship Torpedo Defence System – Ultra S2170	DCS	CTI
Towed Low Frequency Active Sonar – Ultra LFAPS-C	DCS	CTI
Sonobuoy Processing System – General Dynamics Canada	DCS	CTI
Torpedo Setting Panel Mk-331 for Mk-54 Torpedo	FMS	CTI
Integrated Communications System – L3 Harris	DCS	N/A
OSI Maritime – Integrated Bridge System	DCS	N/A
Main Gun System – Leonardo 127-mm Gun, NA-30S MK-2 Fire Control System	DCS	Under development
Secondary Gun System – Leonardo Lionfish 30-mm (x2)	DCS	Under Development

FMS = Foreign Military Sales; DCS = Direct Commercial Sales

Figure 4. Major equipment items and capabilities integrated into CSC, categorized as per the Aegis-CSC Combat System architectural arrangement.

## Navigating the future

The CSC Combat System represents a monumental leap in Canada's warship capabilities, particularly in anti-air warfare and strike missions, fortifying Canada's proud legacy in naval expertise. Leveraging Canadian industry for the Canadian Tactical Interface empowers the RCN to incorporate future weapons and sensors, ensuring adaptability beyond the current Common Source Library shared software reference used by Aegis. The introduction of SPY-7 radar signals a new era of radar technology, offering unprecedented situational awareness and high-quality fire-control track information, revolutionizing operational capabilities.

Beyond its technological prowess, Aegis offers strategic advantages, fostering unparalleled interoperability with key

allies, notably the US Navy. This integration forms a robust foundation for joint operations, amplifying Canada's role within global defence alliances.

Aligning with a proven system such as Aegis not only bolsters Canada's maritime defence capabilities, but also underscores its commitment to shared security responsibilities. This commitment strengthens diplomatic ties, and nurtures strategic partnerships crucial for global security.



*Cdr Robert "Bobby" Gilpin is the Senior Combat Systems Engineering Manager for PMO Canadian Surface Combatant in Ottawa.*



Photo courtesy United States Navy

Key players from the Canadian Surface Combatant Project, Royal Canadian Navy, Public Services and Procurement Canada, United States Navy, and Lockheed Martin Corporation at the USN's Combat Systems Engineering Development Site (CSEDS) in Moorestown, New Jersey on June 21, 2023 for the start of the development of the CSC Aegis computer program. Canada will have an Aegis combat systems integration lab at CSEDS to develop and integrate the CSC Combat System elements in advance of delivery to the Canadian Land Based Test Facility at Hartlen Point, Nova Scotia.

## FEATURE ARTICLE

# A Proposal to Improve Quick Acting Watertight Door Handle Holdbacks

By MS J.N. Besaw

(Technical Advisor: CPO2 William Dollimount)

[\*Adapted from a November 2023 Naval Fleet School (Atlantic) Mar Tech RQ-PO2 0030 course student Technical Service Paper, which contains the author's full list of references.]

The RCN's *Halifax*-class frigates have 40 quick-acting watertight (QAWT) doors installed in heavily transited areas to provide structural integrity, passageway effectiveness, and damage control safety (Figure 1). These doors, which are operated more than any other type of door on board ship, are dogged/undogged using a lever-style handle, and feature a single polyethylene holdback (Figure 2) to prevent the handle from swinging freely while in the opened position. The door handle holdbacks used today were meant to be a solution to the problematic spring clip holdbacks that were previously used, but issues persist with the handles not always being securely held back to prevent possible hand injury to personnel.



Figure 1. Quick-acting watertight door aboard a *Halifax*-class frigate.



Figure 2. The polyethylene holdback currently in use.

For the purpose of satisfying Fleet School Atlantic course requirements, two possible solutions to this problem were investigated. The aim was to improve the current quick action watertight door handle holdback configuration for functionality and safety through better design and increased material strength. Cost estimates for the two options were prepared for the original Technical Service Paper, but will not be detailed here.

## Current configuration and the problem

The current polyethylene door handle holdbacks are configured as shown in Figure 3, and measure approximately  $2 \frac{3}{8} \times 1 \frac{9}{16} \times \frac{1}{2}$  inches. A slit on the front-facing side of the holdback helps reduce resistance when seating the door handle into the rounded notch to keep the handle firmly in place. A  $\frac{9}{32}$ -inch hole located behind the slit allows the holdback to be bolted to an associated steel bracket mounted on the door, which secures it in place.

The current holdback configuration has several design flaws. First, the holdback itself is made of polyethylene. This type of plastic is known for having good flexibility, tensile strength, and resistance to impact. However, due to the amount of impact that comes with frequent use, the holdbacks are prone to failure, particularly in how the handle seats itself in the holdback. Furthermore, this material is also prone to breaking under extreme temperature conditions.

Photos by MS J. Besaw except where noted.

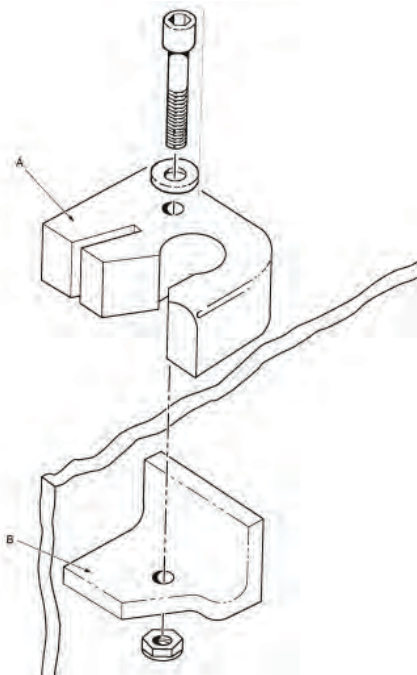

Source: CFTO – C-28-010-329/MS-001, Watertight Closures Inspection, Maintenance and Minor Repairs for Ships Staff, Ottawa, 6 Oct 1998.

Figure 3. Technical drawing of current holdback configuration.



Figure 4. Broken door holdback. The right-hand side of the holdback notch has broken away, preventing the door handle from being secured.

Due to general wear and a loss of rigidity from regular use, these holdbacks do not provide a tight fit for the handles, which can cause them to drop suddenly, leaving personnel susceptible to injury. The point of failure most commonly observed is the break pictured in Figure 4. This is due to it being the thinnest part of the design, yet having to absorb most of the force of the handle's impact.

### Criteria for improving holdbacks

Numerous factors were assessed in identifying two options that could solve the problem of ineffective QAWT door handle holdbacks. Any reconfiguration or replacement materials must:

- Offer sustainable rigidity to the current configuration;
- Provide high impact resistance from repetitive use of the handles;
- Be securable to the current steel bracket configuration;
- Maintain strength under a broad range of temperatures; and
- Be cost-effective.

### Option A—Modifying the existing holdbacks

Option A involves implementing changes to both the material and dimensions of the current holdback design. This would involve using Delrin® polymer, a product of DuPont®. This material offers a variety of advantages when compared to the polyethylene material used for the current holdback, such as increased stiffness, strength in high- and low-temperature conditions, as well as better fatigue, friction, and wear resistance. Increasing the thickness of the holdback to  $\frac{3}{4}$ " from  $\frac{1}{2}$ " would improve its impact resistance, thereby making it less susceptible to breaking without having to modify the steel bracket system currently in place.

This option would be implemented through the resources of the RCN's Fleet Maintenance Facility. Machine shop personnel could fabricate the proposed holdbacks using a Flow Waterjet® system, and ship's staff could install the new holdbacks aboard ship.

### Option B—Replacing the holdbacks

Option B involves replacing the existing holdbacks with Grainger Canada's Zico® standard spring clips (Figure 5), commonly referred to as Terry clips, as the alternative of choice. These heavy-duty steel clips offer numerous benefits when compared with the current polyethylene holdbacks. One of these is the ability to reshape the clips if

*(Continues next page...)*

they no longer provide a snug fit after considerable use. Another benefit of these clips is the durable nature of metal when compared to polyethylene. Under demanding conditions, whether these be broad temperature ranges or repetitive use, the ability for metals to sustain their structural integrity is much higher than that of the current polyethylene holdbacks.

This option would require ship's staff to bore the pre-existing holes in the purchased clips to accommodate  $\frac{1}{4} \times 20 \times \frac{3}{4}$ " bolts, and drill  $\frac{1}{4}$ " holes in the steel bracket that is used to secure the current holdbacks.

## Options analysis

Options A and B both meet all criteria as viable proposals in terms of providing more sustainable rigidity when compared to the current holdback configuration. Each proposal offers high impact resistance from repetitive use of the quick-action watertight door handles. However, due to the design of Option A, the Delrin® polymer holdback would offer more impact resistance when compared to Option B, and could be secured to the steel bracket configuration without any modifications. Both options can withstand a broad range of temperature fluctuations. While both options are cost-effective, Option A (~\$1,500 per ship) was clearly cheaper than Option B (~\$2,500 per ship).

## Summary and recommendations

This Technical Service Paper addresses issues associated with the current QAWT door handle holdback configuration that is prone to failure due to both wear, and to loss of rigidity of the holdbacks themselves, resulting in the handles losing an adequately secure fit within the holdback's rounded notch. The wear and loss of rigidity, along with broad temperature ranges can increase the likelihood of the holdbacks breaking through repetitive impact. These issues can lead to potential injuries of personnel aboard ship.

Both of the investigated options were deemed to be acceptable, with Option A being the less costly fix, requiring less effort and no modification to the existing ship structure. Replacing the current holdbacks with new units manufactured by the FMF using Delrin® polymer could be implemented quickly due to the limited design change of the proposed holdback itself. It is also beneficial that the FMF has the capability to fabricate such holdbacks with little notice, and in bulk if necessary.

It is recommended that an Unsatisfactory Condition Report (UCR) be raised concerning the failures of the current QAWT door handle holdbacks, and that a trial of



Figure 5. Grainger Zico® Standard Spring Clips, commonly referred to as Terry clips.

Option A be conducted on board a designated frigate. Several doors in high-traffic areas should be allocated to have the new holdback configuration installed and monitored periodically, with feedback collected from ship's staff. If this trial is successful, it is recommended that an Engineering Change be pursued.



*Master Sailor Jesse Besaw is a Marine Technician at FMF Cape Scott in Halifax, NS.*

## Acknowledgment

The guidance of my technical supervisor, **CPO2 William Dollimount**, and the assistance of machinist **Kendall Hiltz** from Fleet Maintenance Facility Cape Scott in the preparation of this paper are gratefully acknowledged.



## Titles of Interest

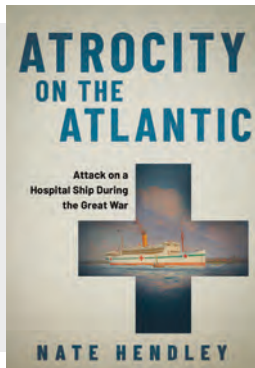

### **Atrocity on the Atlantic: Attack on a Hospital Ship During the Great War**

*How a German submarine sank a Canadian military hospital ship during the First World War and sparked outrage.*

By Nate Hendley

Published (2024) by Dundurn Press, Toronto

Available on Amazon in Paperback, PDF, and e-Pub editions

ISBN: 9781459751347 / 9781459751354 / 9781459751361

240 pages

On the evening of June 27, 1918, HMHS *Llandoverly Castle* — an unarmed, clearly marked hospital ship used by the Canadian military — was travelling from Halifax, NS to Liverpool, UK when it was unlawfully torpedoed off the Irish Coast by the German submarine U-86.

Attacking hospital ships violated international law, so to conceal his actions, U-86 commander Helmut Patzig turned the submarine's deck guns on the survivors. While 234 of the 258 people on board died, including all 14 nursing sisters, one lifeboat escaped with witnesses to the atrocity, triggering global outrage over the attack.

The cowardly and criminal act became a rallying cry, and was the subject of a graphic 1918 Victory Bonds poster. The Nurses' Memorial sculpture installed in Canada's Parliamentary Centre Block Hall of Honour in 1926 is believed to have been inspired in part by N/S Minnie Katherine Gallaher who was lost at sea during the action.

The story, as told by Toronto-based freelance journalist and author Nate Hendley, explains how the sinking of the *Llandoverly Castle* was adjudicated at the 1921 Leipzig War Crimes Trials, resulting in a historic legal precedent that guided subsequent war crime prosecutions, including the Nuremberg Trials following the Second World War. Although the U-boat's commander fled to escape justice, two of his officers were sentenced to four-year prison terms. In 1943, Patzig returned to service as the commander of a *Kriegsmarine* U-boat training flotilla.

*Atrocity on the Atlantic* explores the *Llandoverly Castle* sinking, the people impacted by the attack, and the reasons why this wartime atrocity has been largely forgotten by Canadians.

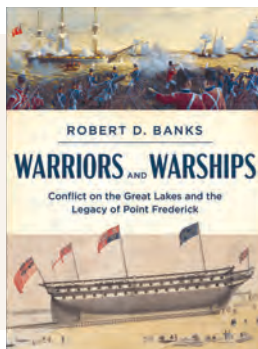

### **Warriors and Warships**

*Conflict on the Great Lakes and the Legacy of Point Frederick*

By Robert D. Banks

Published (2023) by Dundurn Press, Toronto

Available on Amazon in Paperback, PDF, and e-Pub editions

ISBN: 9781459750777 / 9781459750661 / 9781459750678

368 pages

In *Warriors and Warships*, author Robert Banks brings to life a fascinating part of Canada's late 18<sup>th</sup> to mid-19<sup>th</sup> century military history – the story of the warships, and the people of Upper Canada who built them, to stop invasion and bring about peace. Situated opposite Kingston, ON, the

Point Frederick peninsula was the 1789 dockyard home of the Provincial Marine on Lake Ontario, and the headquarters of Britain's Royal Navy from 1813 to 1853. Today, it is the home of the Royal Military College of Canada.

*(Continues next page...)*

In this detailed narrative, featuring more than one hundred colour archival maps, aerial views, photographs, and 3D reconstructions, Banks (a 1974 RMC graduate) recounts Point Frederick's era of constructing great sail and steam warships, and the roles these vessels played in conflicts on Lake Ontario and the St. Lawrence River. Among the conflicts is the War of 1812, when French Canadian and British shipwrights made warships that forced the U.S. Navy into port and led to the American withdrawal from Canada. Banks also covers the role of the ships in the settlement of Upper Canada, the rebellion of 1837, the early planning of the Rideau Canal, and the beginning of the undefended border.

Along the way, Banks introduces an array of people from Upper Canada, such as Lieutenant Governor John Graves Simcoe and his wife, Elizabeth Posthuma; Governor General Lord Dorchester; General Isaac Brock; Sir James Yeo, and even Charles Dickens. He also describes the day-to-day activities at Point Frederick, beyond shipbuilding and military campaigns, such as skating parties, sleigh rides, theatricals, disease and death, and crime and punishment.

Banks shares the moments of hardship, triumph, and tragedy of both the warriors and the warships in this important contribution to Canadian history.



## NEWS BRIEFS

### Night move for HMCS *Corner Brook*

By Rory Theriault

On the night of Jan. 12/13, 2024, with temperatures plunging below -20 degrees Celsius, and winds cutting through the darkness, HMCS *Corner Brook* (SSK-878) was cold moved by tugs from the FMF Cape Breton dry dock to an alongside berth in the Esquimalt, BC naval dockyard. The undocking marked a significant milestone in the *Victoria*-class submarine's ongoing refit program.

Since entering dry dock last July (see MEJ 106), more than 55,000 hours of maintenance and systems upgrade work was completed to ensure the submarine meets the highest operational standards when it returns to service. The expertise of the FMF's qualified trades personnel ensured that everything from engineering to electronics was meticulously addressed before *Corner Brook* commenced the next phase of work.

Undocking a submarine in the biting cold and heavy winds was no small feat, but the skilled crews of HMCS *Corner Brook* and the King's Harbour Master pilot and civilian-operated tugs, along with support from the FMFCB team, turned what could have been a challenging endeavour into a resounding success. The undocking of an RCN submarine in the dead of winter symbolized not just a triumph over adverse weather, but a broader victory for naval maintenance and operational readiness.



*Rory Theriault is the Strategic Communications Officer for the Navy's two fleet maintenance facilities.*



Photo: LCdr Jimmy Lau

Photos: MS Michelle Chowns

HMCS *Corner Brook* (SSK-878) is guided by tugboats as it relocates from dry dock to a berth alongside FMF Cape Breton in January to commence the next phase of its refit program.



## NEWS BRIEFS

### Growing capabilities at FMF Cape Scott with new underwater technology

By Gabrielle Brunette

Last November, FMF Cape Scott successfully used its new Oceanbotics™ SRV-8 remotely operated vehicle (ROV) during Syncrolift docking operations for HMCS *Montréal* (FFH-336) at the Halifax, NS naval dockyard.

The SRV-8 vehicle is equipped with a camera and sonar, while a user-operated mobile pilot station allows for complete control over the ROV's movements underwater. Weighing just over 18 kg, and with a 91-metre tether, the small box-shaped robot is particularly useful in bodies of water with low visibility.

“It’s very convenient for us to be able to see exactly where the ship is at any given time,” said FMFCS Docking Officer **David Humphries**. “When we go to raise the Syncrolift, we know that everything’s sitting properly on the keel blocks.”

During a typical docking evolution, the initial alignment of the ship over the keel blocks is done using out-of-water alignment points. The docking team estimates the proper placement of the ship using visual markers, after which the docking officer must rely on divers from the Fleet Diving Unit to verify the position of the ship underwater. This process requires clear communication, and often requires multiple dives and realignments before the ship is in proper position.

“Now we have the option of sending the ROV down and relaying video back so we can adjust the alignment and see results in real time,” Humphries said.



Oceanbotics™ SRV-8 remotely operated vehicle.



Photos courtesy FMF Cape Scott

Equipped with a camera and sonar system, the SRV-8 remotely operated vehicle facilitated the docking alignment process for HMCS *Montréal* by allowing the docking team to see the ship's position underwater in real time. The ROV has already proven its versatility on other tasks.

While the ROV helps facilitate the alignment aspect of the docking process, it does not entirely eliminate the need for divers. For other activities, however, it has already relieved some of the pressure and demand on the Fleet Diving Unit by replacing divers normally required for conducting underwater inspections of ships and harbour mooring buoys.

The technology isn't new, but it is the first of its kind across the fleet maintenance facilities. According to FMFCS Combat Systems Engineering Officer **Steve Watters**, the SRV-8 is an asset that can be used by many different departments for such tasks as conducting video surveys, and assisting in sonar performance trials.

“The ROV provides more independence for FMFCS to conduct surveys and get information quicker than previously. It enables us to be more effective and efficient in support of the fleet,” he said.



*Gabrielle Brunette is the Junior Communications Officer at Fleet Maintenance Facility Cape Scott in Halifax, NS.*



# NEWS (SPRING 2024)

Canadian Naval Technical History Association

*CNTHA News*  
Est. 1997

**CNTHA Chairman**  
Pat Barnhouse

**CNTHA Executive Director**  
Tony Thatcher

**Directorate of History and Heritage Liaison**  
Lt(N) Jason Delaney

**Maritime Engineering Journal Liaison**  
Brian McCullough

**Webmaster**  
Peter MacGillivray

**Webmaster Emeritus**  
Don Wilson

*CNTHA News* is the unofficial newsletter of the Canadian Naval Technical History Association. Please address all correspondence to the publisher, attention Lt(N) Jason Delaney, Directorate of History and Heritage, NDHQ 101 Colonel By Dr Ottawa, ON K1A 0K2 Tel. (613) 998-7045 Fax (613) 990-8579

Views expressed are those of the writers and do not necessarily reflect official DND opinion or policy. The editor reserves the right to edit or reject any editorial material.

[www.cntha.ca](http://www.cntha.ca)

## Déjà vu: Looking Back at the Story of the Wartime Wreck of HMCS *Athabaskan*

By Brian McCullough

On the 80<sup>th</sup> anniversary of the loss of a Canadian Tribal-class destroyer to enemy action in the English Channel on April 29, 1944, the CNTHA invites readers to revisit a story that ran in the Summer 2006 edition of the *Maritime Engineering Journal* (MEJ 60): "Exploring the Wartime Wreck of HMCS *Athabaskan* — A Naval Architect's Adventure in Underwater Archaeology."

[https://publications.gc.ca/collections/collection\\_2015/mdn-dnd/D12-21-60-eng.pdf](https://publications.gc.ca/collections/collection_2015/mdn-dnd/D12-21-60-eng.pdf)

<https://www.cntha.ca/static/documents/mej/mej-60.pdf>

Written by **LCdr Jocelyn Turgeon**, a serving naval officer from 1986 to 2008, and a continuing member of the RCN's Naval Technical support community with DND until 2022, the story documents two dive expeditions that took place in 2003 and 2005 to examine the Second World War wreckage of HMCS *Athabaskan* (G07). Barely a year after being commissioned into service at Newcastle-on-Tyne, UK, the ship was attacked off the coast of Brittany by a German Elbing-class torpedo boat, and sent to the bottom in 90 metres of water.

The search for the missing stern section to determine what caused the mysterious second explosion that killed the ship known as the "Unlucky Lady" was unsuccessful, but the enterprise achieved its other goals of relocating, imaging, and mapping the wreckage, and placing a commemorative plaque at the site to honour the 128 officers and men who were lost. Of the survivors, 44 were rescued by sister ship HMCS *Haida* (G63), and 83 were taken prisoner.

The story describes a poignant moment as expedition diver Mark Ward and his father Peter—the grandson and son of *Athabaskan* crewmember Lt. Leslie Ward who was lost with the ship—were "united" for the first time at the wreck site:

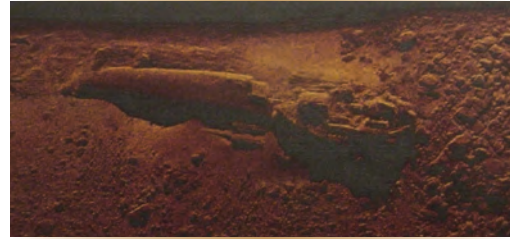

Image courtesy: French naval hydrographic service GESMA

Side-scan sonar image of the *Athabaskan* wreck in 2004.

As Mark Ward...placed the memorial plaque onto *Athabaskan's* remains on the sea bottom, his own father Peter sat in a boat nearly 90 metres overhead. It was the closest that the three Wards—father Peter, and the son and grandfather who had never known one another—would ever come to being together.

In 2014, through the initiative of Merchant Navy veteran, **Captain Paul Bender**, the wreck was declared a maritime cultural asset by the French government, and formally placed under the protection of the Republic of France. The Government of Canada will be consulted before any archaeological projects are ever given authorization to work at the site.

People looking for a closer connection to the *Athabaskan* story on this side of the Atlantic can visit the HMCS *Haida* National Historic Site in Hamilton, ON ([haida.info@pc.gc.ca](mailto:haida.info@pc.gc.ca)). The Parks Canada museum ship is the only surviving Tribal-class destroyer in existence.

For more information about HMCS *Athabaskan* (G07), go to: [http://www.forposterityssake.ca/Navy/HMCS\\_ATHABASKAN\\_G07.htm](http://www.forposterityssake.ca/Navy/HMCS_ATHABASKAN_G07.htm)

See also, "Looking Back: Memories of an *Athabaskan* Bride," by Iolanda (Vi) Connolly (MEJ 73):

[https://publications.gc.ca/collections/collection\\_2014/mdn-dnd/D12-21-73-eng.pdf](https://publications.gc.ca/collections/collection_2014/mdn-dnd/D12-21-73-eng.pdf)

<https://www.cntha.ca/static/documents/mej/mej-73.pdf>



Athabaskan image courtesy DND Directorate of History and Heritage